

PLATINUM RESISTANCE TEMPERATURE SENSORS

BASIC TECHNICAL DESCRIPTION, USER MANUAL CERTIFICATE

1. General information

Resistance thermometers with Pt-100, Pt-500 or Pt-1000 sensors are designed for temperature measurement and are used as sub-assembly of heat meter.

Temperature sensors type according to EN1434: PL – pocket mounted long probes.

Temperature sensors according to EN 60751+A2:2000 are selected as matched pairs according to EN1434:2007.

Temperature sensors pair corresponds to essential requirements of the Technical Regulation for Measuring Instruments, dated 30 March 2006, transposing in the law Directive 2004/22/EC of 31 March 2004 on measuring instruments:

- Annex I Essential requirements

- Annex MI-004 Heat meter ,

Type numbers (and the corresponding order code) reference example:

Type	PL6	-	□	□	□	□	□	-	□□*
Pt-designation:	Pt100	-1							
	Pt500	-2							
	Pt1000	-3							
Connection method:	2-wire	-2							
	4-wire	-4							
Connection cable length, m:	3	-5	or	10					
Temperature sensors pair:									P
Temperature sensors pair MI004 :									PM
Individual sensor:									(none) -
Mounting set (pocket, boss, and sealing ring) depending on the diameter of the pipeline (DN20, DN25, DN32, DN40, DN50, DN65, DN80, DN100, DN125, DN150, DN200):									DN20... DN200
No mounting set:									(ommitted) -

Note: * - This sign on the code, are used, only for ordering (It is not used for sensor marking).

2. Technical data

Temperature measurement range	0°C ... 150 °C.
Temperature difference measurement range	3°C ... 100 °C.
Maximum admissible temperature of medium	150 °C
Tolerance class	B according to EN 60751
Connection cable length for 4-wire connection	5m, 10m
Connection cable length for 2-wire connection	3m, 5m, 10m (for Pt500 and Pt1000) 5m (only for Pt100)
Cable type for 4-wire connection	Not shielded, 4 x 0,35mm ² (connected permanently)
Cable type for 2-wire connection	Not shielded, 2 x 0,5mm ² (connected permanently)
Maximum permissible RMS value of sensor current	0,5 mA
Response time $\tau_{0,5}$	< 10 s.
Total resistance of signal leads (2-wire connection)	0,22 Ω - for wire length 3m 0,36 Ω - for wire length 5m 0,72 Ω - for wire length 10m
Environmental	Ambient temperature +5°C... +55°C Mechanical environment class M1 Electromagnetic environment class E1

3. Complete set

		Amount, pcs
1	Temperature sensors pair (double pair or individual sensor) PL	2 (3; 1)
2	Mounting set	2 (3; 1), (may not be ordered)
3	Technical description, user manual, certificate	1

4. Dimensional drawing

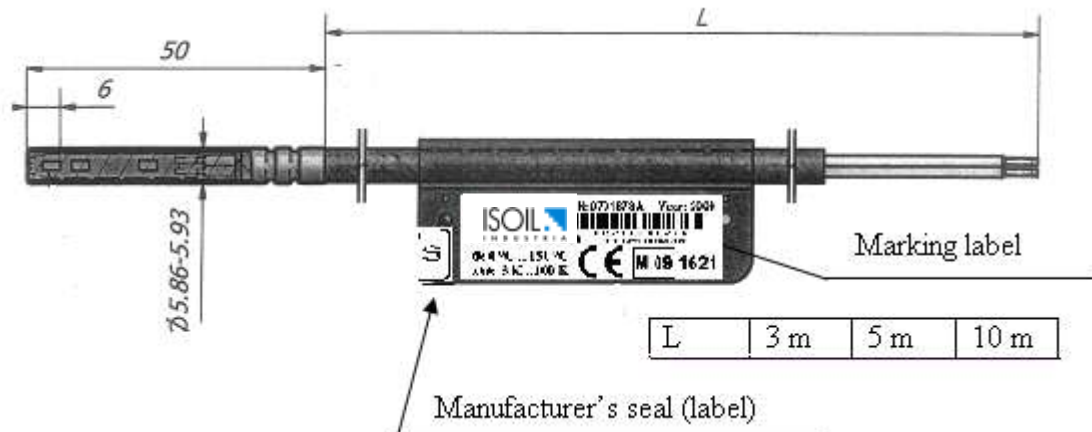

Fig.4.1. Sensor dimensions

5. Operating principle

Temperature sensors PL is a platinum resistance temperature sensors. Temperature sensor output parameter is electrical resistance. The operating principle is based on change of electric resistance of sensing element proportionally to change of temperature of the measured medium. Resistance dependence on temperature of medium, depending on the Pt-designation, according to EN 60751.

6. Mounting of sensors.

Temperature sensors PL are fitted by means of suitable length protective pocket (Fig.6.1)

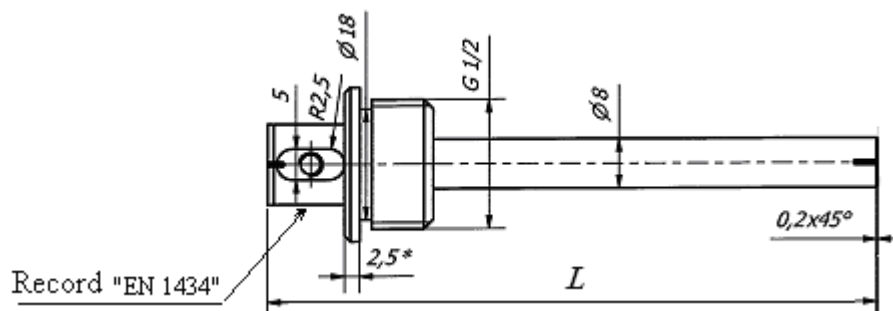

Nominal diameter of pipe, mm	Overall length of protective pocket L, mm
DN20...DN100	100
DN125...DN150	135
DN200	225

Fig.6.1. Protective pocket

and suitable type and length of a boss (Fig.5.2 and Fig.5.3).

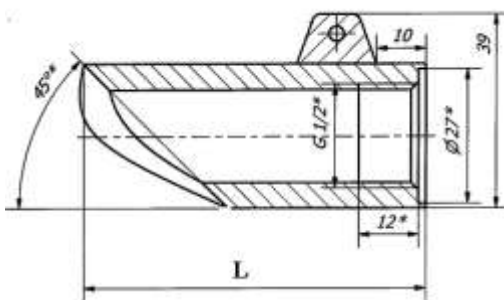

Fig.6.2. Example of boss for pipes sizes DN < 65 mm

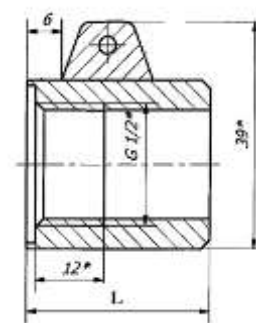

Fig.6.3. Example of boss for pipes sizes DN ≥ 65 mm

Nominal diameter of pipe, mm	L, mm
DN20	79,3
DN25	69
DN32, DN40	59
DN50	49

Nominal diameter of pipe, mm	L, mm
DN65, DN80, DN125, DN150	32
DN100	18
DN200	90

For installation in pipes with sizes $DN < 65\text{mm}$ the temperature sensor is mounted with 45° angle to pipe axis by means of sensor pocket (Fig. 6.4a). The sensor pocket is chosen according to nominal size of pipe (Fig.6.2). The temperature sensor must be inclined downstream and the sensing element must be inserted to pipe axis or beyond.

For installation in pipes with sizes $DN \geq 65$ the temperature sensor is mounted perpendicular to pipe axis by means of sensor pocket (Fig. 6.4b). The sensor pocket is chosen according to nominal size of pipe (Fig.6.3). The temperature sensing element must be inserted to pipe axis or beyond.

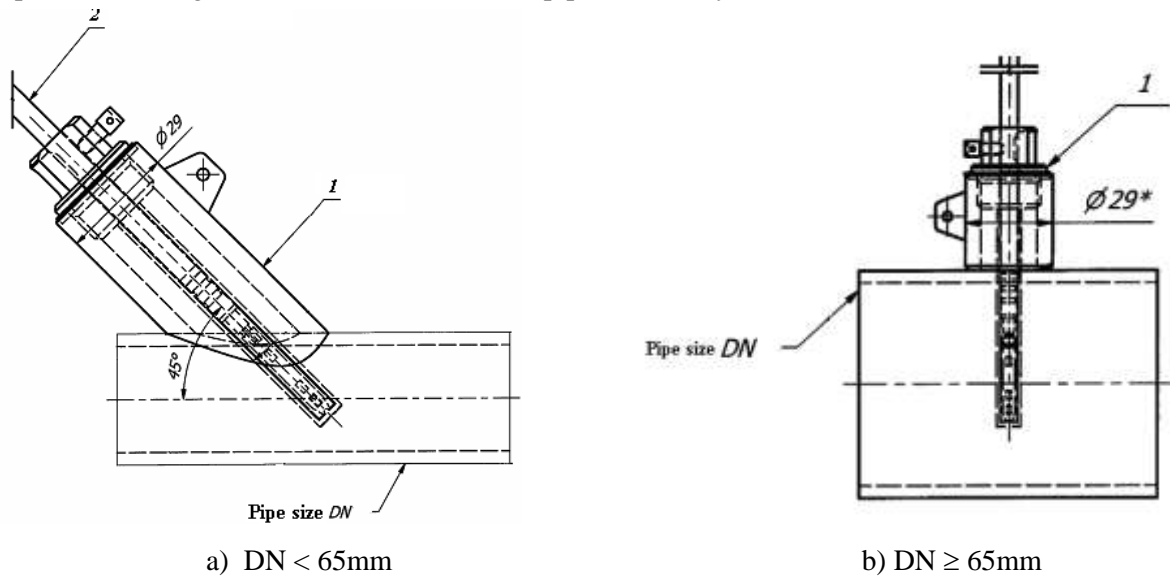

Fig.6.4. Temperature sensors fitting examples depending on the pipe size

Installation recommendations:

1. The suitable boss (1) is welding,
2. The protective pocket together with ring (gasket) is screwing by means of a wrench (dog-hook),
3. The temperature sensor (2) is fitting into protective pocket, plunging up to the end
4. The fixing bolt is fully screwing.

After mounting of the temperature sensors by means of a pendant seal are sealed up a sensors installation site(see Fig.6.5).

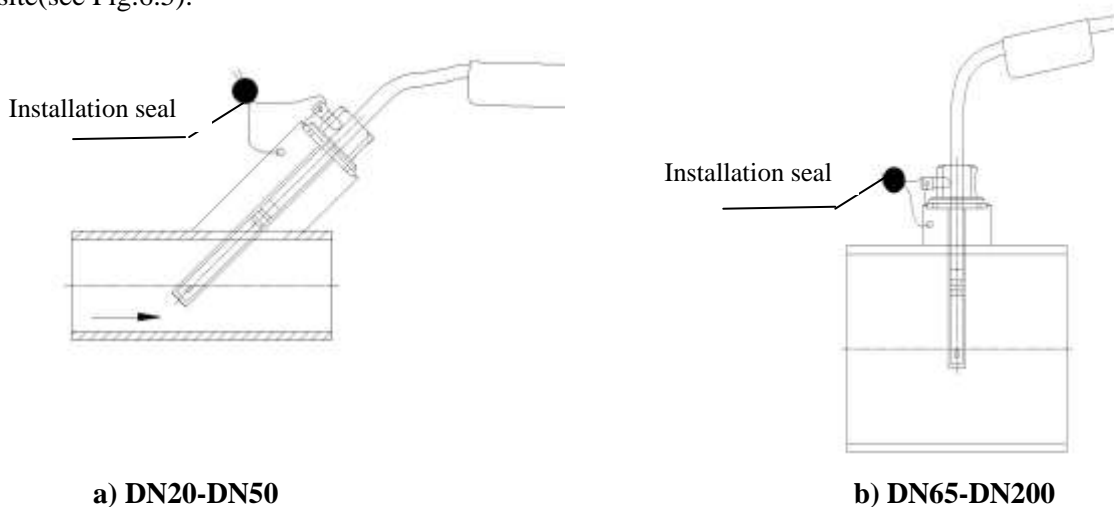
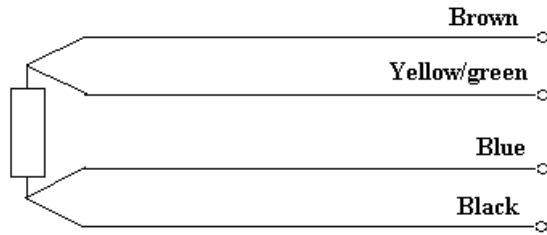

Fig.6.5. Temperature sensors sealing examples

At Installation of temperature sensors on equal diameters of pipes symmetric installation of both sensors (the same method of installation, the same immersion depth) should be provided.

Colour performance of the connection cable wires for 4-wire connection method is presented below:



7. Marking and security seals

The following information are on the marking label of the temperature sensor:

- manufacturer's trade mark,
- type and type identification number—inclusive Pt-designation (Pt100,Pt500or Pt1000),
- serial number,
- year of manufacture,
- limits of temperature range (Θ_{\min} and Θ_{\max}),
- limits of temperature differences ($\Delta\Theta_{\min}$ and $\Delta\Theta_{\max}$),
- maximum admissible working pressure,
- EC-type examination certificate number.

The pocket of temperature sensor is marked with „EN 1434“ according EN 1434-2:2007 (see Fig.6.1).

Serial number of temperature sensor consists of six digits and the letter. The pair or double pair of temperature sensors has the same number and the several letters:

XXXXXX „A“ – temperature sensor is used for flow temperature measurement. The base of marking label is red,
 XXXXXX „B“ – temperature sensor is used for return temperature measurement. The base of marking label is blue,

XXXXXX „C“ – temperature sensor is selected as matched pair with flow temperature sensor and is used for measurement of liquid temperature in replenishment or in second return line. The base of marking label is blue,

Security seals:

Manufacturer seals:

- The marking label should be sealed as shown in fig. 4.1.

Installation seal:

- The installation site of temperature sensors in the pipeline should be sealed as shown in fig. 6.6

8. Warranty

Warranty period of temperature sensors service - 24 months from the time of the sale date

The company performs warranty service only in this case: the sensor seals are undamaged, the sensor mechanically is not damaged, the sensor service was carried out strictly under requirements of this instruction

Warranty service does not include verification of sensors.

CERTIFICATE

Temperature sensors pair (double pair,individual sensor) corresponds to EN 60751+A2:2000, EN 1434 requirements and corresponds to essential requirements of the Technical Regulation for Measuring Instruments, dated 30 March 2006 transposing in the country law Directive 2004/22/EC of 31 March 2004 on measuring instruments.

Sensor Nr. _____ Sensor Nr. _____ Sensor Nr. _____

Date of manufacture _____

 Position Name Signature

Date of sale _____